

MiniTech

Installation instructions



Table of contents

TABLE OF CONTENTS	2
MODELS AND CHARACTERISTICS	3
ACCESSORIES	3
AUDIT AND PROGRAMMING ACCESSORIES	3
CERTIFICATIONS	4
IMPORTANT NOTES!	4
KEYPAD DIMENSIONS	6
SWINGBOLT LOCK DIMENSIONS	6
DEADBOLT LOCK DIMENSIONS	7
LATCHBOLT LOCK DIMENSIONS	8
MOTORLOCK LOCK DIMENSIONS	8
MOTOR LATCHBOLT LOCK DIMENSIONS	9
FIXED KEYPAD INSTALLATION INSTRUCTIONS	9
SWINGBOLT LOCK INSTALLATION INSTRUCTIONS	10
DEADBOLT AND LATCHBOLT LOCKS INSTALLATION INSTRUCTIONS	11
MOTORLOCK AND MOTOR LATCHBOLT LOCKS INSTALLATION INSTRUCTIONS	13
CONNECTION EXAMPLES	15
FUNCTIONAL TESTS	16
CE DECLARATIONS	17
CORRECT DISPOSAL OF THIS PRODUCT:	20
(WASTE ELECTRICAL & ELECTRONIC EQUIPMENT)	20
CONTACTS	20

MiniTech

Models and characteristics

Model	Variant
T9520/GR – Keypad in metal. Grey colour with rubber membrane foil keypad in grey colour.	/DL with Dallas key reader.

Accessories

Code	Description
T20019/T	Cabling interface/Adapter.
L4001	Large battery box for 6 size C 1,5V batteries.
N620/A	9V Battery box with alarm interface.
T6006	Power supply interface 12 ÷ 24 V with alarm interface.
L2666	Knob with 6 mm square spindle.
N1982	User Dallas key.
N10017/01 and /02	Open Device with led and buzzer (N10017/01) or with led only (N10017/02). Usable only on lock 2.

Audit and programming accessories

Code	Description
N42180/T	USB interface.
N42170/D	Dallas key reader with molex connector.
N42170/J	Dallas key reader with jack connector.

N42170/M	Magnetic Dallas key connection cable.
N1996RM	Magnetic Dallas key for audit.
T42146/J	Setup and audit cable.

Certifications

The updated product certifications are available on the official websites of Tecnosicurezza:

www.tecnosicurezza.it www.tecnosicurezza.es www.usatecno.com

Important notes!

- Before installing this product, please read carefully the installation and operating instructions.
- Locks can be installed in all traditional safes.
- Lock has to be mounted on secure storage metal (preferred steel) units only.
- Locks must be protected against external attacks, for this reason it is recommended to install them on the door away from any through holes (except DeadBolt and MotorLock).
- If locks are not properly protected by systems belonging to the safe (manganese plates, glass plate, relocking, etc.) only DeadBolt and MotorLock locks can be mounted behind the passage hole for the connection cable or the spindle.
- Any electronic part must be properly protected and not easily accessible even when the door is open.
- Locks have been developed to work correctly in a temperature range from -5 ° C to + 50 ° C and in an environment with non-condensing humidity between 25% and 90%.
- The mounting dimensions are standard (magic module).
- For keypad and lock installation, use only the screws provided by Tecnosicurezza. Any other screw must be approved in advance.
- Locks are supplied with metric (M6) mounting screws. Upon request, Imperial 1/4-20 UNC format mounting screws are available.

MiniTech

- The type of material and the length of the screws must, in any case, be selected so as to guarantee long life and reliability.
- Tighten the screws so that the lock is firmly fixed to the mounting surface (recommended torque between 2,5 and 5,5 Nm).
- The mounting surface must be perfectly flat.
- In order to prevent the screws from loosening, it is recommended the use of LOCTITE® threadlocker and/or specific washers positioned under the head of the fixing screw.
- The diameter of the passage hole for the connection cable or the spindle must not exceed 11 mm.
- The hole must be completely cleaned of drill dust and sharp edges.
- Do not lubricate locks.
- In the locked position, the distance between the bolt and the boltwork part which moves the lock bolt must comply with the following specifications for each type of lock.
- Any component to be fixed to the lock bolt must be previously approved by Tecnosicurezza before installation. In any case, the maximum load must not exceed 4 N for T5201/M and 30 N for the reinforced model T5201/MP.
- Secure the cables away from moving parts by using cable ties and cable ties bases.
- If placed in normal domestic or office environments, the locks do not require particular maintenance; in any case, after 10,000 opening/closing cycles, it is recommended to run a test that verifies the correct and complete operation of the product.
- Use only DURACELL™ 9 Volt Alkaline batteries, or battery holders with DURACELL™ 1,5 Volt Alkaline batteries. Alternatively it is also possible to use a stabilized power supply from 12 V to 24 V and 1 A, with relative power supply interface (p.n. T6006).
- A series of acoustic signals during opening indicate a low battery level. In this case, the battery must be replaced.
- Do not use cleaning agents with chemical, abrasive or alcohol-containing additives to clean the components. Use only a damp cloth.
- Do not spray liquid directly onto the components.

Keypad dimensions

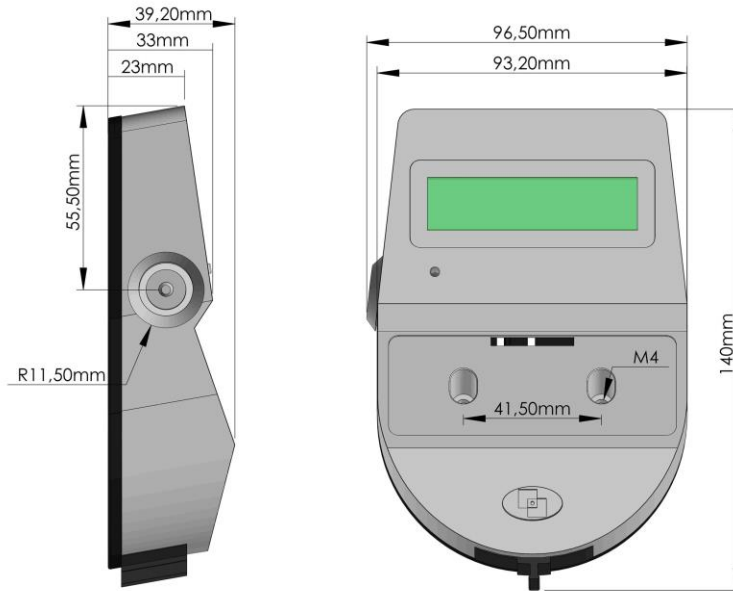

STANDARD mounting



VERTICAL mounting

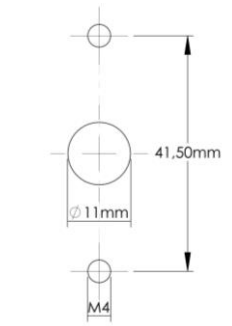

SwingBolt Lock dimensions

T5201

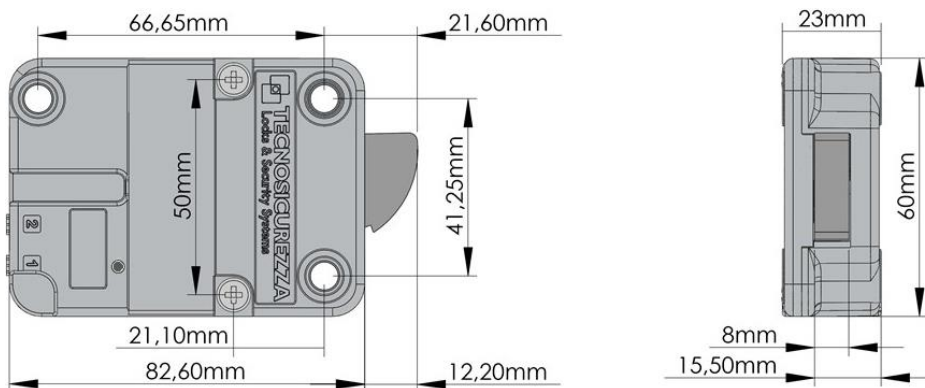

MiniTech

T5200

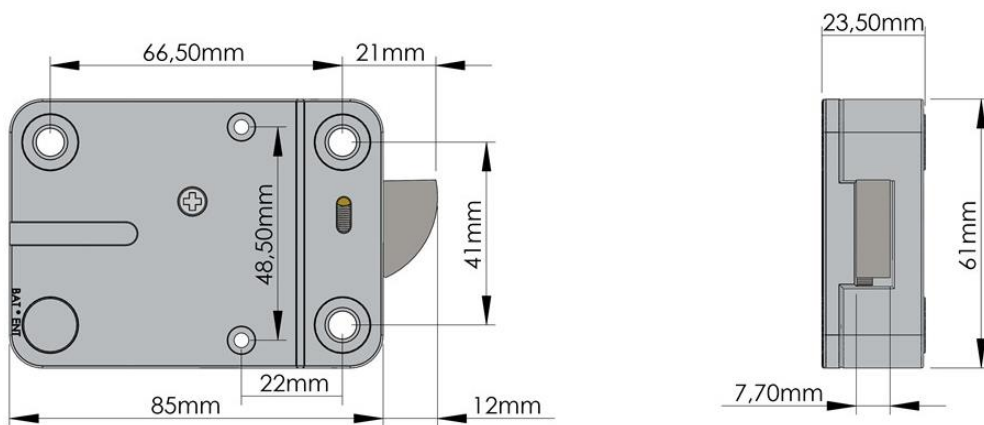

DeadBolt lock dimensions

T5201/D

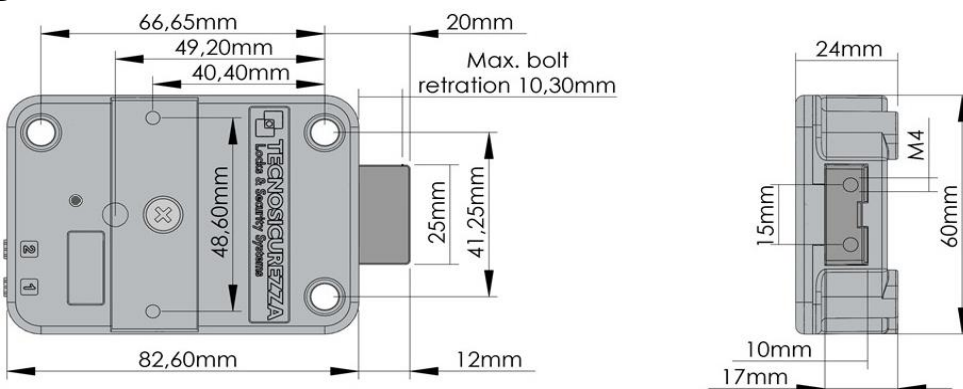

T5200/D

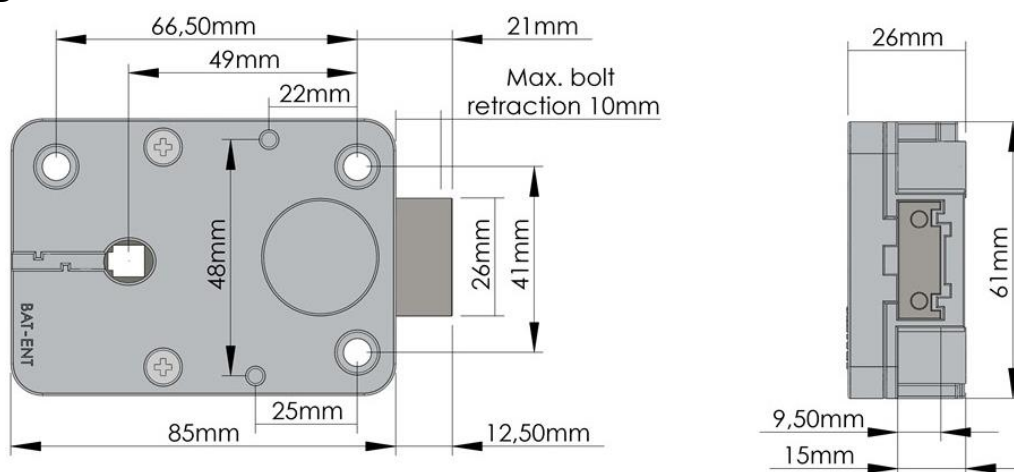

LatchBolt lock dimensions

T5201/S

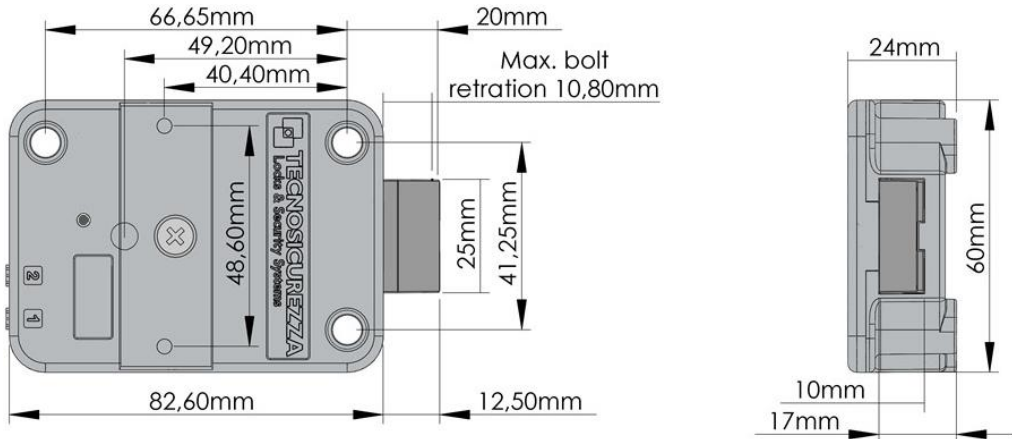

T5200/S

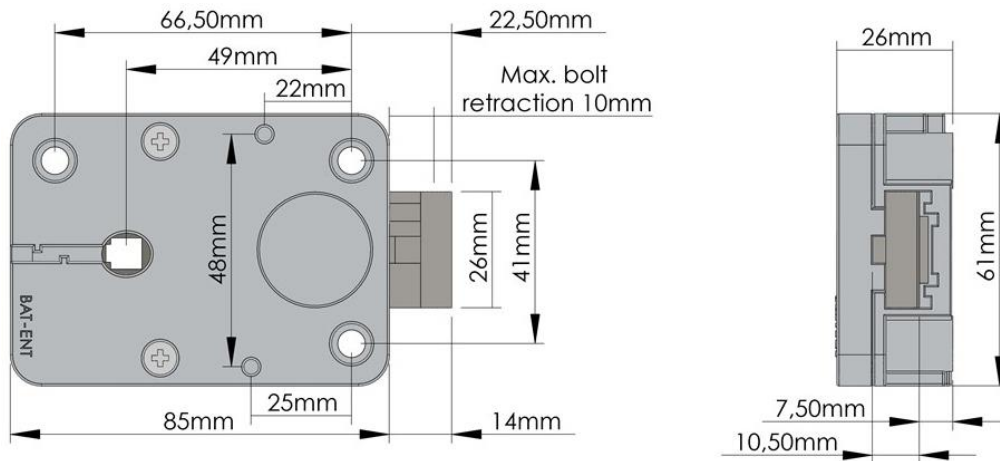

MotorLock lock dimensions

T5201/M & T5201/MP

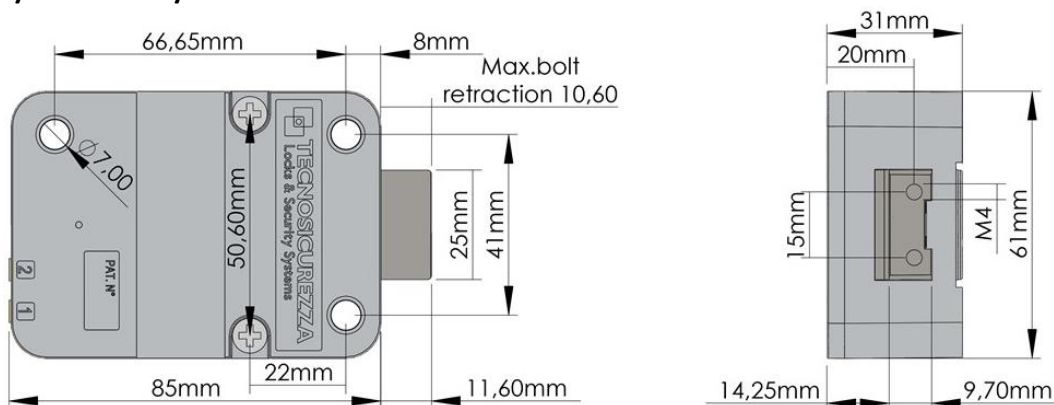

MiniTech

Motor LatchBolt lock dimensions

T5201/M/S

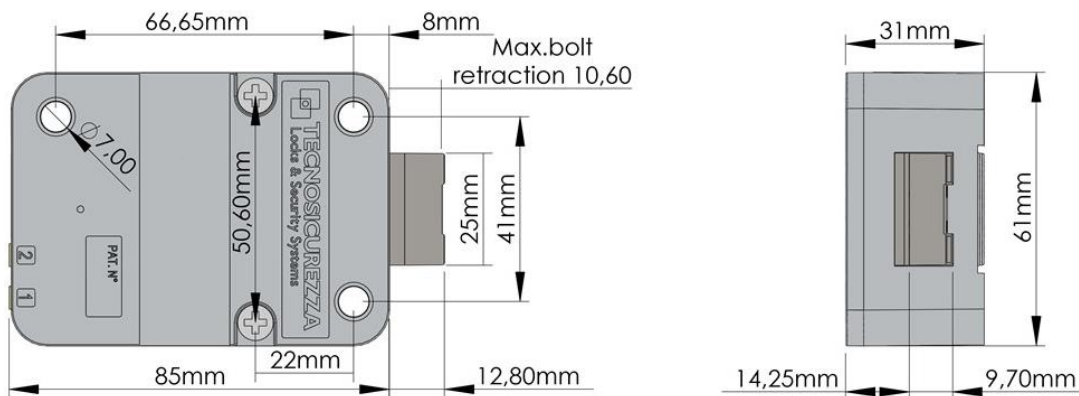

Fixed keypad installation instructions

Insert the keypad cable inside the hole on the safe door and connect it to the lock connector "1/ENT". Lift the keypad membrane and, making sure that the connection cable and the battery cable are not damaged by the keypad case, fix the screws to the relative threaded holes on the safe door.



STANDARD mounting



VERTICAL mounting

The keypad can also be installed in a quick hooking/unhooking mode (vertical mounting).

Remove the release liner placed under the membrane and apply the latter on the keypad case. Connect a battery to the battery connector inside the keypad battery compartment or, if provided, connect the battery pack to the lock connector "2/BAT".



SwingBolt lock installation instructions

The SwingBolt lock is a swinging bolt lock whose block is carried out by a motor; it can be installed in all 4 directions, even upside down.

By entering a valid code, the lock electronic removes the blocking for 3 seconds and the boltwork can be moved into open position by pushing the bolt inside the lock case.

The bolt automatically secures when the safe handle, or the safe door mechanism, is brought to the locked position.

If the SwingBolt is used in conjunction with other locks, the safe door mechanism must ensure the closure of the SwingBolt before the other locks.

The lock can be mounted in all four mounting directions (RH, LH, VU, VD).

Furthermore, by flipping over the lock, both locking directions can be realized.

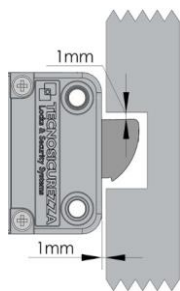

In the locked position the distance between the lock's bolt and the lock part that moves the lock bolt should be approximately 1 mm.

The bolt must be able to move freely without force being applied to it.



The maximum load applicable to the bolt must not exceed 1 KN. Contact Tecnosicurezza in case of heavier loads.

Connect the keypad cable to the lock connector "1/ENT", making sure it is fully inserted and locked.

Any alarm interface or battery holder needs to be connected to the lock connector "2/BAT". To remove the cable, bring the connector upwards and carefully pull it out.

It's possible to connect a relocker to the lock cover through the appropriate holes.

Fix the relocker plate with M4 self tapping flat head screws. Length must be 6mm + plate thickness.

(i.e. 6 mm + 2 mm plate = 8 mm screw)



MiniTech

DeadBolt and LatchBolt locks installation instructions

DeadBolt and LatchBolt locks are locks with, respectively, a dead bolt and a spring bolt, whose block is carried out by a motor.

By entering a valid code, the lock electronic removes the blocking for 3 seconds and the boltwork can be moved into open position by turning the spindle inserted in the lock.

The spindle can be connected to a knob, a handle or directly to the keypad if equipped with a rotation kit. When the spindle is brought to the locked position, the bolt comes out ensuring the lock is locked.

The DeadBolt and LatchBolt locks can be mounted in all four mounting directions (RH, LH, VU, VD).

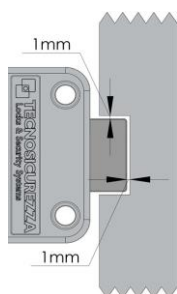

In the locked position, there should be approximately 1 mm clearance between the lock bolt and the cavity in the blocking bar of the boltwork. The bolt must be able to move freely without force being applied to it.

In open position, there should be a minimum of 3 mm and maximum of 5 mm clearance between the lock bolt and the blocking bar of the boltwork.



The maximum load applicable to the bolt must not exceed 1 KN. Contact Tecnosicurezza in case of heavier loads.

The LatchBolt lock is specially designed to ensure self locking when the door closes.

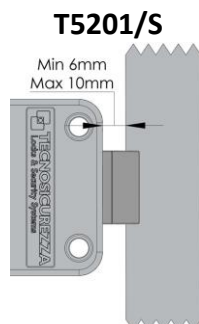

The distance between the LatchBolt lock and the locking edge must be between a minimum of 6 mm and a maximum of 10 mm.

MiniTech

The distance between the LatchBolt lock and the locking edge must be between a minimum of 3 mm and a maximum of 8 mm.

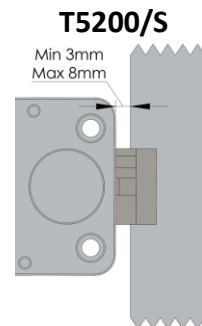

When locked, there must be a 0.5 mm gap between lock bolt and locking surface.

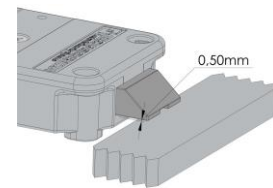

Cut the spindle to the correct length (measure door thickness + mounting plate/rotation knob or handle insert + lock spindle insert).

Remove any cutting residues of the spindle that could damage the cable.

T5201/D & T5201/S locks

The spindle needs to be fully inserted inside the lock (7 mm).

Place the cable in the groove of the spindle, making sure it's fully inserted and locked.

Secure the cable inside the special groove located under the lock body, ensuring that it is not stretched when turning the spindle.

Fix the lock using the appropriate mounting screws.

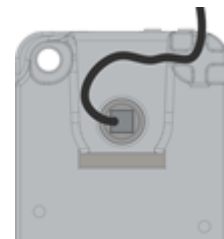

Connect the keypad cable to the lock connector "1", making sure it is fully inserted and locked. Any alarm interface or battery holder needs to be connected to the lock connector "2". To remove the cable, bring the connector upwards and carefully pull it out.

T5200/D & T5200/S locks

The spindle must be inserted between a minimum of 7 mm to a maximum of 12 mm inside the lock.

WARNING: do not insert the spindle up to the lid of the lock, but leave some margin to allow the movement of the cable and to prevent any damage.

Place the cable in the groove of the spindle, making sure it's fully inserted and locked.

Insert the cable connector into the square hole present in the bottom of the lock and make it come out from the opposite side.

MiniTech

Secure the cable inside the special groove located on the lock cover, ensuring that it is not stretched when turning the spindle. Fix the lock using the appropriate mounting screws.

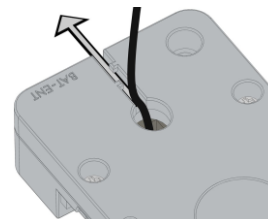

Connect the keypad cable to the lock connector "ENT", making sure it is fully inserted and locked. Any alarm interface or battery holder needs to be connected to the lock connector "BAT". To remove the cable, bring the connector upwards and carefully pull it out.

It's possible to connect a relocker to the lock cover through the appropriate holes.

Fix the relocker plate with M4 self tapping flat head screws. Length must be 6 mm + plate thickness.

(i.e. 6 mm + 2 mm plate = 8 mm screw)



MotorLock and Motor LatchBolt locks installation instructions

MotorLock and Motor LatchBolt locks are locks with, respectively, a motor driven dead bolt and a motor driven spring bolt, whose block is carried out by a motor.

By entering a valid code, the motor retracts the bolt which remains in the open position for about 8 seconds and then automatically returns to the locked position.

If the manual relocking option is selected, the bolt closes by pressing and holding the button . Both lock versions can be mounted in all four mounting directions (RH, LH, VU, VD).

Locks are supplied with metric (M6) mounting screws. Upon request, Imperial 1/4-20 UNC format mounting screws are available.

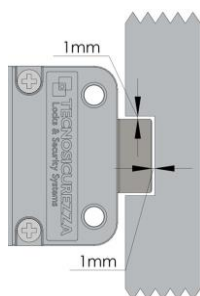

In the locked position, there should be approximately 1 mm clearance between the lock bolt and the cavity in the blocking bar of the boltwork. The bolt must be able to move freely without applying any force on it.

In open position, there should be a minimum of 3 mm and maximum of 5 mm clearance between the lock bolt and the blocking bar of the boltwork.

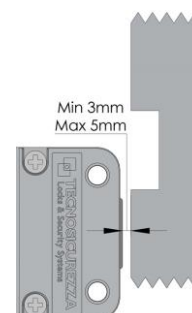

MiniTech

The latch version (Motor LatchBolt lock) is specially designed to ensure self-locking when the door closes.

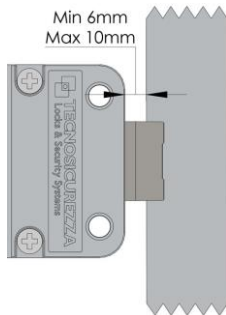

The distance between the LatchBolt lock and the locking edge must be between a minimum of 6 mm and a maximum of 10 mm.

When locked, there must be a 0.5 mm gap between lock bolt and locking surface.

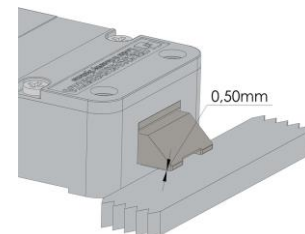

Insert the keypad cable into the lock connector "1", making sure it is fully inserted and locked.

Any alarm interface or battery holder needs to be connected to the lock connector "2". To remove the cable, bring the connector upwards and carefully pull it out.

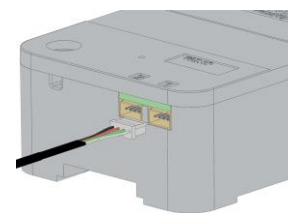

The Push & Pull version (T5201/MP) is supplied by default with RCS option, where closing is triggered by an external signal (i.e. boltwork switch). This avoids the motor to be activated when boltworks are not expanded yet.

It's recommended to correctly use this signal to avoid motor damages.

Lock is also programmed by default with 8 seconds automatic reclosure, which can be modified upon request. This means that if the lock will open but the external signal don't (i.e. boltworks not expanded), lock will automatically close after 8 seconds (smart reclosure).

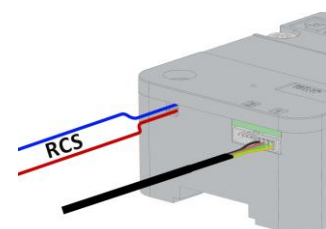

The maximum load applicable to the bolt must not exceed the limit values specified in the table below. Contact Tecnosicurezza in case of heavier loads.

Lock reference	Lock version	Maximum force to apply on the bolt	Maximum load pulled up and pushed by the bolt
T5201/M	Pull and spring version – Cass B	1 KN (100 Kg)	4 N (400 gr)
T5201/MP	Push and pull version – Class B	1 KN (100 Kg)	30 N (3 Kg)
T5201/M/S	Latch version	1 KN (100 Kg)	-

MiniTech

It's possible to connect a relocker to the lock cover through the appropriate holes.

Fix the relocker plate with M4 self tapping flat head screws.
Length must be 6 mm + plate thickness.

(i.e. 6 mm + 2 mm plate = 8 mm screw)



Connection examples

- Double lock connection with 9V battery.

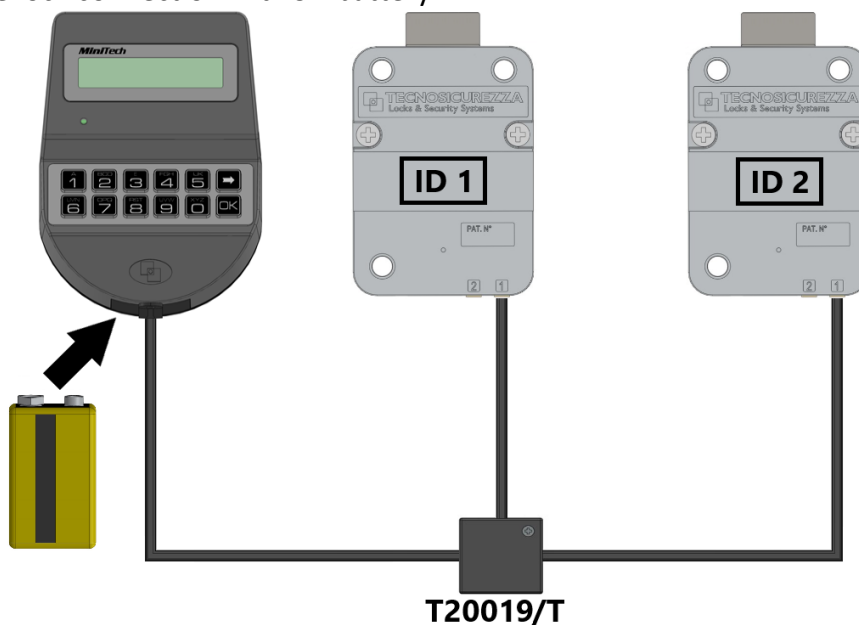

- Double lock connection with external power supply (T6006 interface).

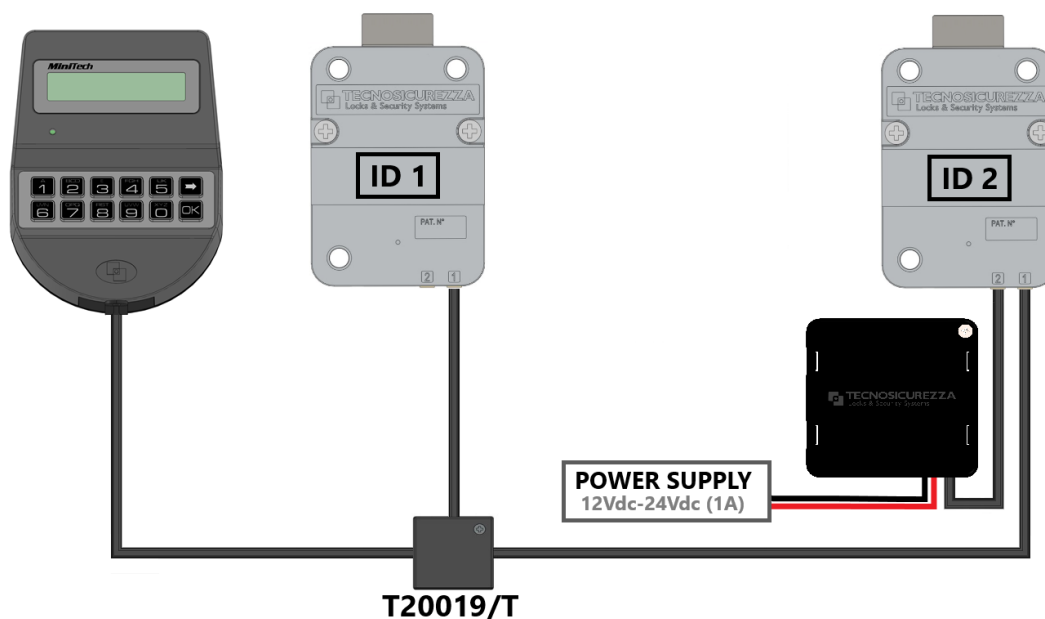

Functional tests

To be carried out with the door open.

MEMBRANE TEST:

Press and hold the button 5 to access the "Membrane Test" function.

Press slowly all the buttons according to the sequence shown on the display.

ELECTRONIC / MECHANICAL TEST:

OPENING:

Enter the opening code (standard manager code 123456). The display will show "open" and the green LED will light up.

With SwingBolt and MotorLock locks, turn the safe door handle to the open position.

With DeadBolt and LatchBolt locks, rotate the knob or handle according to the type of installation and move the lock bolt to the open position.

For all types of locks the bolt must be able to move freely.

LOCKING:

With SwingBolt and MotorLock locks, turn the safe door handle to the locked position. Lock bolt must fully extend and ensure locking.

With MotorLock locks with manual relocking, turn the door handle towards the locked position and press the button .

Lock bolt must fully extend and ensure locking.

With DeadBolt lock, rotate the knob or handle according to the type of installation and move the lock bolt to the locked position.

Lock bolt must fully extend and ensure locking.

Make sure that there is free space in all directions around the bolt when the movement is brought to the locked position.

Repeat the functional test several times before closing the safe door.

Failure to follow these installation instructions or opening the lock by personnel not authorized by Tecnosicurezza will void the warranty.

MiniTech

CE declarations

DICHIARAZIONE CE DI CONFORMITA' CE DECLARATION OF CONFORMITY

MiniTech: T952-x

Il sottoscritto Franco Miller, in veste di Presidente CdA e Legale Rappresentante della società **Tecnosicurezza S.p.A.**, con sede in San Giovanni Lupatoto (Verona) Via Cesare Battisti 276, dichiara sotto la propria responsabilità, che il suddetto prodotto soddisfa per progettazione e costruzione i requisiti delle direttive di: compatibilità elettromagnetica **2014/30/UE** e RoHS 2 **UE/2015/863**. La conformità è stata verificata con l'ausilio delle seguenti norme armonizzate:

EN 61000-6-3, EN50130-4, EN 61000-4-2, EN 61000-4-3, EN 61000-4-4, EN 61000-4-5, EN 61000-4-6, EN 61000-4-11, EN 61000-6-1, EN55022

The undersigned Mr Franco Miller as Chairman and Legal Representative of the company **Tecnosicurezza S.p.A.**, located in San Giovanni Lupatoto (Verona) Via Cesare Battisti 276, declare herewith on our own responsibility that the above-mentioned product meets the requirements of the **UE/2015/863** RoHS 2, **2014/30/UE** Electromagnetic Compatibility for what concerns engineering and construction. Conformity has been controlled with the aid of the following harmonized standards:

EN 61000-6-3, EN50130-4, EN 61000-4-2, EN 61000-4-3, EN 61000-4-4, EN 61000-4-5, EN 61000-4-6, EN 61000-4-11, EN 61000-6-1, EN55022

Verona - Italy, 02/10/2018

Franco Miller
Board Chairman

Tecnosicurezza Sp.A



(firma, signature)

**DICHIARAZIONE CE DI CONFORMITA'
CE DECLARATION OF CONFORMITY**

MiniTech: T52-xx

Il sottoscritto Franco Miller, in veste di Presidente CdA e Legale Rappresentante della società **Tecnosicurezza S.p.A.**, con sede in San Giovanni Lupatoto (Verona) Via Cesare Battisti 276, dichiara sotto la propria responsabilità, che il suddetto prodotto soddisfa per progettazione e costruzione i requisiti delle direttive di: compatibilità elettromagnetica **2014/30/UE** e RoHS 2 **UE/2015/863**. La conformità è stata verificata con l'ausilio delle seguenti norme armonizzate:

EN 61000-6-3, EN50130-4, EN 61000-4-2, EN 61000-4-3, EN 61000-4-4, EN 61000-4-5, EN 61000-4-6, EN 61000-4-11, EN 61000-6-1, EN55022

The undersigned Mr Franco Miller as Chairman and Legal Representative of the company **Tecnosicurezza S.p.A.**, located in San Giovanni Lupatoto (Verona) Via Cesare Battisti 276, declare herewith on our own responsibility that the above-mentioned product meets the requirements of the **UE/2015/863** RoHS 2, **2014/30/UE** Electromagnetic Compatibility for what concerns engineering and construction. Conformity has been controlled with the aid of the following harmonized standards:

EN 61000-6-3, EN50130-4, EN 61000-4-2, EN 61000-4-3, EN 61000-4-4, EN 61000-4-5, EN 61000-4-6, EN 61000-4-11, EN 61000-6-1, EN55022

Verona - Italy, 02/10/2018

Franco Miller
Board Chairman

Tecnosicurezza Sp.A

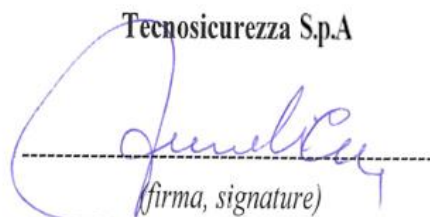

(firma, signature)

Correct disposal of this product:

(Waste Electrical & Electronic Equipment)

Applicable in the European Union and other European countries with separate collection systems.



This marking displayed on the product or its literature indicates that it should not be disposed with other wastes at the end of its working life.

To prevent possible harm to the environment or human health from uncontrolled waste disposal, please separate this from other types of wastes and recycle it responsibly to promote the sustainable reuse of material resources.

Contacts

GLOBAL HEADQUARTERS

Tecnosicurezza SpA

Via Cesare Battisti. 276
37057 San Giovanni Lupatoto
Verona

Tel.+39 045 826 64 70

Fax. +39 045 826 64 69

info@tecnosicurezza.it

USA HEADQUARTERS

Tecnosicurezza Inc.

50, Thomas Lane
Versailles, KY 40383

Tel.+1 859 490 89 30

info@usatecno.com

SPAIN HEADQUARTERS

Tecnosicurezza Sa

C/Menor, 4 - Nave 10
Pol. Ind La Mina 28770
Colmenar Viejo

Tel.+34 91 804 33 91

Fax.+34 91 804 32 63

info@tecnosicurezza.es